

PULSACOIL 2000

DESIGN, INSTALLATION AND SERVICING INSTRUCTIONS

PLEASE LEAVE THESE INSTRUCTIONS IN THE POCKET PROVIDED ON
THE BACK OF THE FRONT PANEL

Gas Council Approved Reference Numbers

PulsaCoil 125 97-317-31
PulsaCoil 145 97-317-32
PulsaCoil 185 97-317-33
PulsaCoil 215 97-317-34
PulsaCoil 235 97-317-35



*The code of practice for the installation,
commissioning & servicing of central heating systems*

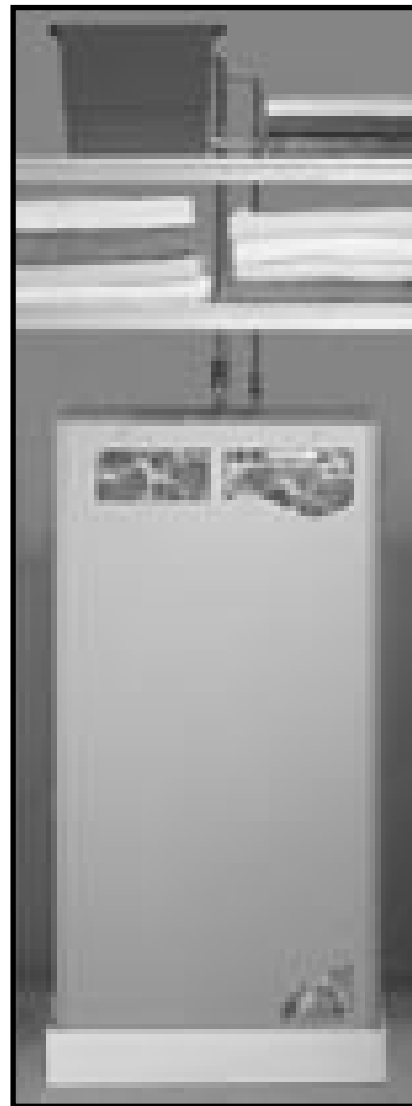
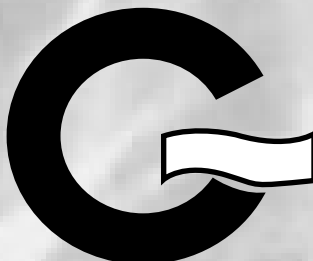

**A MAINS PRESSURE HOT WATER SUPPLY
SYSTEM INCORPORATING AN OFF PEAK
ELECTRIC THERMAL STORE**

**ALL MODELS COMPLY WITH THE
WATER HEATER MANUFACTURERS
SPECIFICATION FOR THERMAL STORES**

CONTENTS

ISSUE 7: 01-03

| Section | Page |
|-------------------------|------|
| 1.0 DESIGN | |
| 1.1 Introduction | 3 |
| 1.2 Technical Data | 5 |
| 1.3 System Details | 9 |
| 2.0 INSTALLATION | |
| 2.1 Site Requirements | 13 |
| 2.2 Installation | 14 |
| 2.3 Commissioning | 18 |
| 3.0 SERVICING | |
| 3.1 Annual Servicing | 20 |
| 3.2 Changing Components | 20 |
| 3.3 Short Parts List | 21 |
| 3.4 Fault Finding | 22 |
| Appendix A | 24 |
| Appendix B | 25 |
| Terms & Conditions | 28 |



*The code of practice for the installation,
commissioning & servicing of central heating systems*

As part of the industry wide "Benchmark" Initiative all Gledhill PulsaCoils now include a Benchmark Installation, Commissioning and Service Record Log Book. Please read carefully and complete all sections relevant to the appliance installation. The details of the Log Book will be required in the event of any warranty work being required. There is also a section to be completed after each regular service visit. **The completed Log Book and these instructions should be left in the pocket provided on the back of the front panel.**

The Gledhill PulsaCoil range is a WBS listed product and complies with the WMA Specification for hot water only thermal storage products. The principle was developed originally in conjunction with British Gas. This product is manufactured under a BS EN ISO 9002 Quality System audited by BSI.

The Gledhill Group's first priority is to give a high quality service to our customers.

Quality is built into every Gledhill product and we hope you get satisfactory service from Gledhill.

If not please let us know.

1.0 DESIGN

1.1 INTRODUCTION

Any water distribution system/installation must comply with the relevant recommendations of the current version of the Regulations and British Standards listed below:-

Building Regulations
Requirements for Electrical Installations
Water Regulations
Manual Handling Operations Regulations

British Standards
BS6700 and BS7671.

A competent person must install the PulsaCoil domestic hot water system. The manufacturer's notes must not be taken as overriding statutory obligations.

The PulsaCoil 2000 is not covered by section G3 of the current Building Regulations and is therefore not notifiable to Building Control.

The information in this manual is provided to assist generally in the selection of equipment. The responsibility for the selection and specification of the equipment must however remain that of the customer and any Designers or Consultants concerned with the design and installation.

Please Note: We do not therefore accept any responsibility for matters of design, selection or specification or for the effectiveness of an installation containing one of our products unless we have been specifically requested to do so.

All goods are sold subject to our Conditions of Sale, which are set out at the rear of this manual.

In the interest of continuously improving the PulsaCoil range, Gledhill Water Storage Ltd reserve the right to modify the product without notice, and in these circumstances this document, which is accurate at the time of printing, should be disregarded. It will however be updated as soon as possible after the change has occurred.



1.0 DESIGN

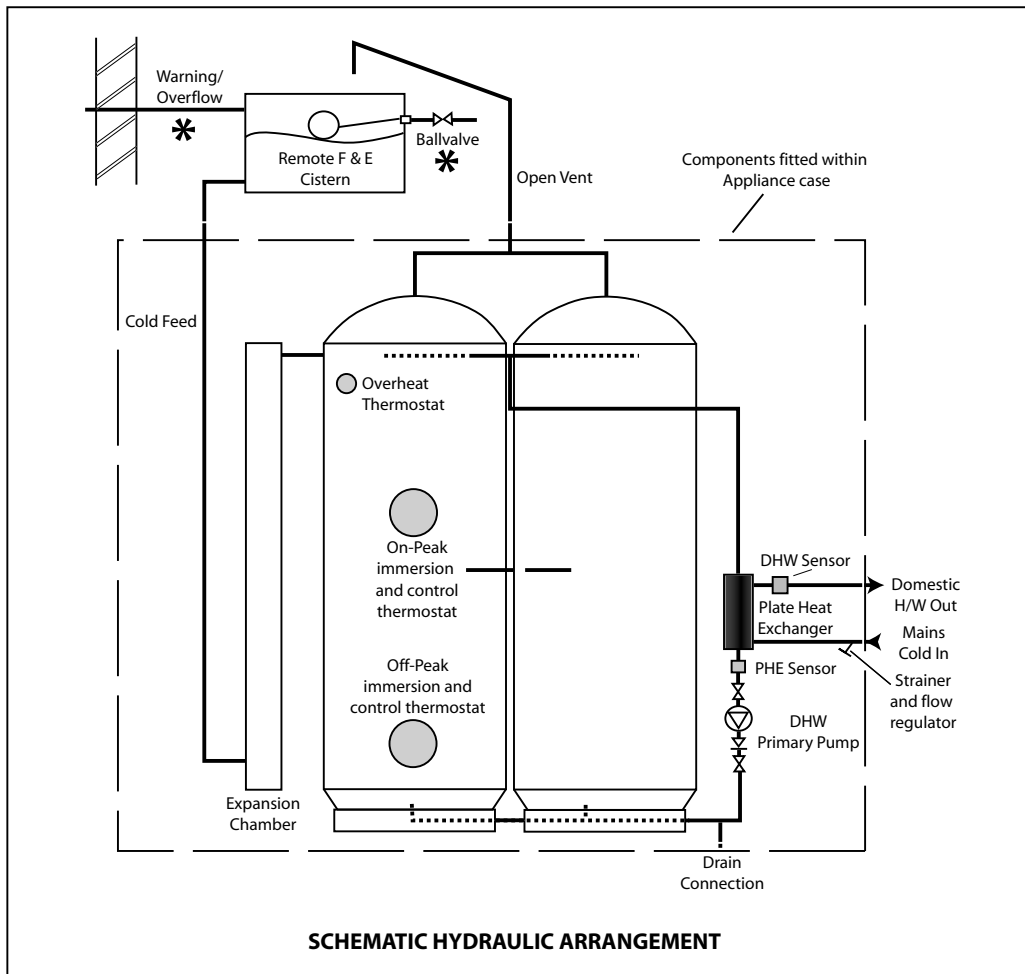

1.1 INTRODUCTION

Description

The Pulsacoil 2000 shown schematically above is designed to provide an improved method of supplying mains pressure hot water when used with a suitable off peak electric supply/tariff.

The PC 125 model is only provided with one off peak immersion heater and it is only recommended for use when an Economy 10 or Heatwise tariff is available - see model selection guide on page 5 for details.

Because of the efficiency of the appliance improved SAP ratings can be achieved. Further details are available from the Gledhill Technical Department.

An important feature of the concept is that hot water can be supplied directly from the mains at conventional flow rates without the need for temperature and pressure relief safety valves or expansion vessels. This is achieved by passing the mains water through a plate heat exchanger. The outlet temperature of the domestic hot water is maintained by the Pump Speed Control (P.S.C.) board, which controls the speed of the pump circulating the primary water from the store through the plate heat exchanger.

The PSC incorporates the facility to automatically run the D.H.W. primary pump for about 3 seconds every 30 hours to help prevent it sticking.

Because of the innovative method of hot water production no in-line scale reducer is normally required on the cold supply to the appliance.

If scale should become a problem the plate heat exchanger is easily isolated and replaced with a service exchange unit.

*** Note: The standard appliance is supplied as a manual fill model i.e. without a ballvalve and overflow which makes it particularly suitable for use in flats/apartments. A ballvalve and overflow fitting can be supplied as an optional extra if required.**

1.0 DESIGN

1.2 TECHNICAL DATA

| New Model Range | | PC125 | PC145 | PC185 | PC215 | PC235 |
|---|-----------|----------|----------|----------|----------|----------|
| Appliance Weight | | | | | | |
| -Empty- | (Kg) | 60 | 62 | 68 | 71 | 74 |
| -Full- | (Kg) | 175 | 202 | 238 | 261 | 294 |
| Volume of water heated (on-peak heater) | (litres) | n/a | 65 | 65 | 70 | 75 |
| MCW & DHW Pipe connections | (mm) | 22 | 22 | 22 | 22 | 22 |
| Cold feed/expansion connection | (mm) | 15 | 15 | 15 | 15 | 15 |
| Safety open vent connection | (mm) | 22 | 22 | 22 | 22 | 22 |
| Drain connection | | R 1/2" | R 1/2" | R 1/2" | R 1/2" | R 1/2" |
| Maximum head | (m) | 10 | 10 | 10 | 10 | 10 |
| Hot water flow rate | (lts/min) | up to 35 | up to 35 | up to 35 | up to 35 | up to 35 |

| MODEL SELECTION GUIDE | | | | |
|-------------------------------|--------------|-------|-------|-------|
| Dwelling Type | | | | |
| Bedroom | 1 - 2 | 2 - 3 | 2 - 3 | 2 - 4 |
| Bathrooms | 1 or 1 | 1 | 1 | 2 |
| En-Suite shower rooms | | 1 | 2 | 1 |
| Standard Economy 7 tariff | PC145 | PC185 | PC215 | PC235 |
| Economy 10 or Heatwise tariff | PC125 | PC125 | PC145 | PC185 |

Notes:-

1. Plastic feed and expansion cistern will be supplied separately including ballvalve, float and overflow fitting.
2. The flow rates are based on a 35°C temperature rise and assume normal pressure and adequate flow to the appliance. The actual flow rate from the appliance is automatically regulated to a maximum of 28 litres/min.
3. Unit is supplied on a 100mm high installation base.
4. The domestic hot water outlet temperature is automatically regulated to approximately 55°C at the bath flow rate of 18 litres/min recommended by BS 6700. The temperature is not user adjustable.

1.0 DESIGN

1.2 TECHNICAL DATA

Standard Equipment

The standard configuration of the PulsaCoil 2000 is shown opposite. The Pump Speed Control Board (P.S.C.), mounted inside the appliance, controls the operation of the complete system. The P.S.C. is pre-wired to a terminal strip where all electrical connections terminate. It is supplied with the following factory fitted equipment:-

1. 3kW off-peak immersion heater with rod thermostat
2. 3kW on-peak boost immersion heater with rod thermostat
3. Pump Speed Control Board (P.S.C.)
4. Plate heat exchanger
5. Domestic hot water primary (plate heat exchanger) pump
6. Commissioning Link (L1) - for dry fire protection
7. DHW temperature sensor
8. PHE return sensor
9. Overheat thermostat and reset button
10. Strainer and flow regulator
11. Screwed connection for a drain tap
12. A feed and expansion cistern complete with cold feed/open vent pipework assembly is supplied separately.

Note : Both immersion heaters are low watts density type with incoloy 825 sheaths and are specially manufactured to suit Thermal Stores. It is recommended that any replacements should be obtained from Gledhill Water Storage.

Optional Extra Equipment

- Flexible connectors for quick connection to first fix pipe installation. For further details see 2.2 Installation, Pipework connections.
- Hot and cold water manifolds for use with plastic pipework.
- Ballvalve/overflow connector for F & E cistern

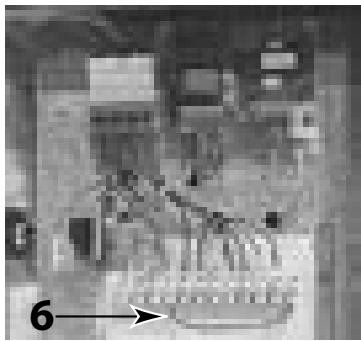
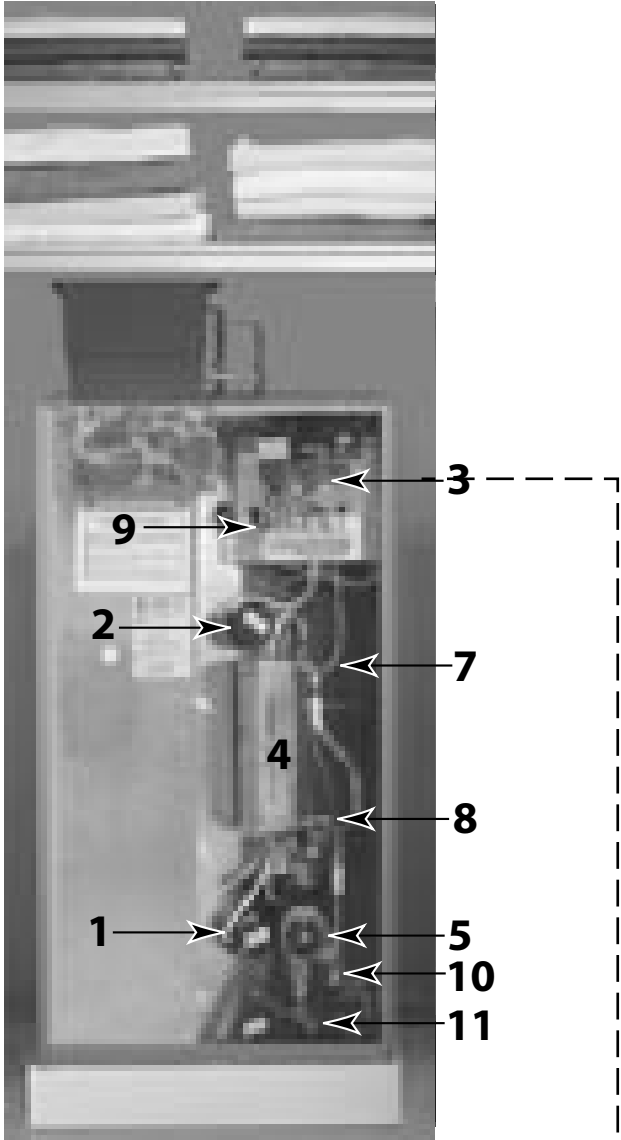

Pump Speed Control Board
P.S.C

1.0 DESIGN

1.2 TECHNICAL DATA

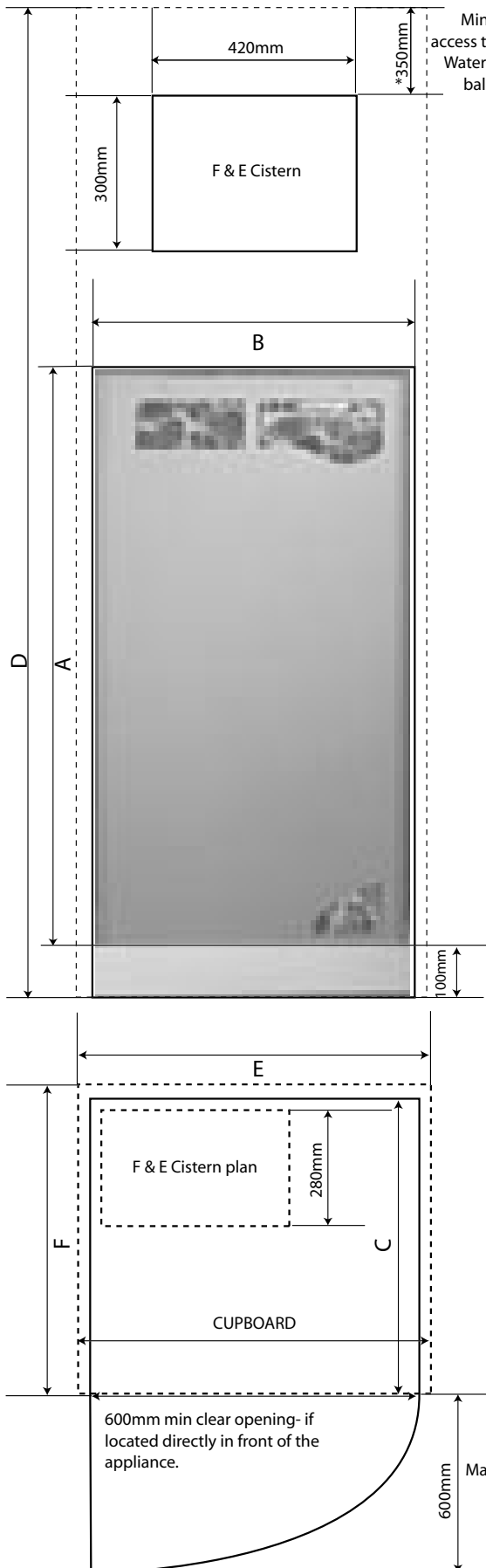

| APPLIANCE DIMENSIONS | | | |
|----------------------|--------|-------|-------|
| Model | Height | Width | Depth |
| | A | B | C |
| PC 125 | 1015mm | 595mm | 575mm |
| PC 145 | 1140mm | 595mm | 575mm |
| PC 185 | 1360mm | 595mm | 575mm |
| PC 215 | 1500mm | 595mm | 575mm |
| PC 235 | 1700mm | 595mm | 575mm |

Note: The Appliance dimensions above do not allow for the 100mm high installation base

The following table of minimum cupboard dimensions only allow the minimum space required for the appliance (including the F & E cistern). Any extra space required for shelving etc in the case of airing cupboards etc must be added.

| MINIMUM CUPBOARD DIMENSIONS | | | |
|-----------------------------|--------|-------|-------|
| Model | Height | Width | Depth |
| | D | E | F |
| PC 125 | 1765mm | 700mm | 600mm |
| PC 145 | 1890mm | 700mm | 600mm |
| PC 185 | 2015mm | 700mm | 600mm |
| PC 215 | 2250mm | 700mm | 600mm |
| PC 235 | 2450mm | 700mm | 600mm |

Note: The above dimensions are based on the Appliance and the F & E cistern (fitted with a ballvalve) being in the same cupboard. If the manual fill method is chosen the heights can be reduced by 125mm.

1.0 DESIGN

1.2 TECHNICAL DATA

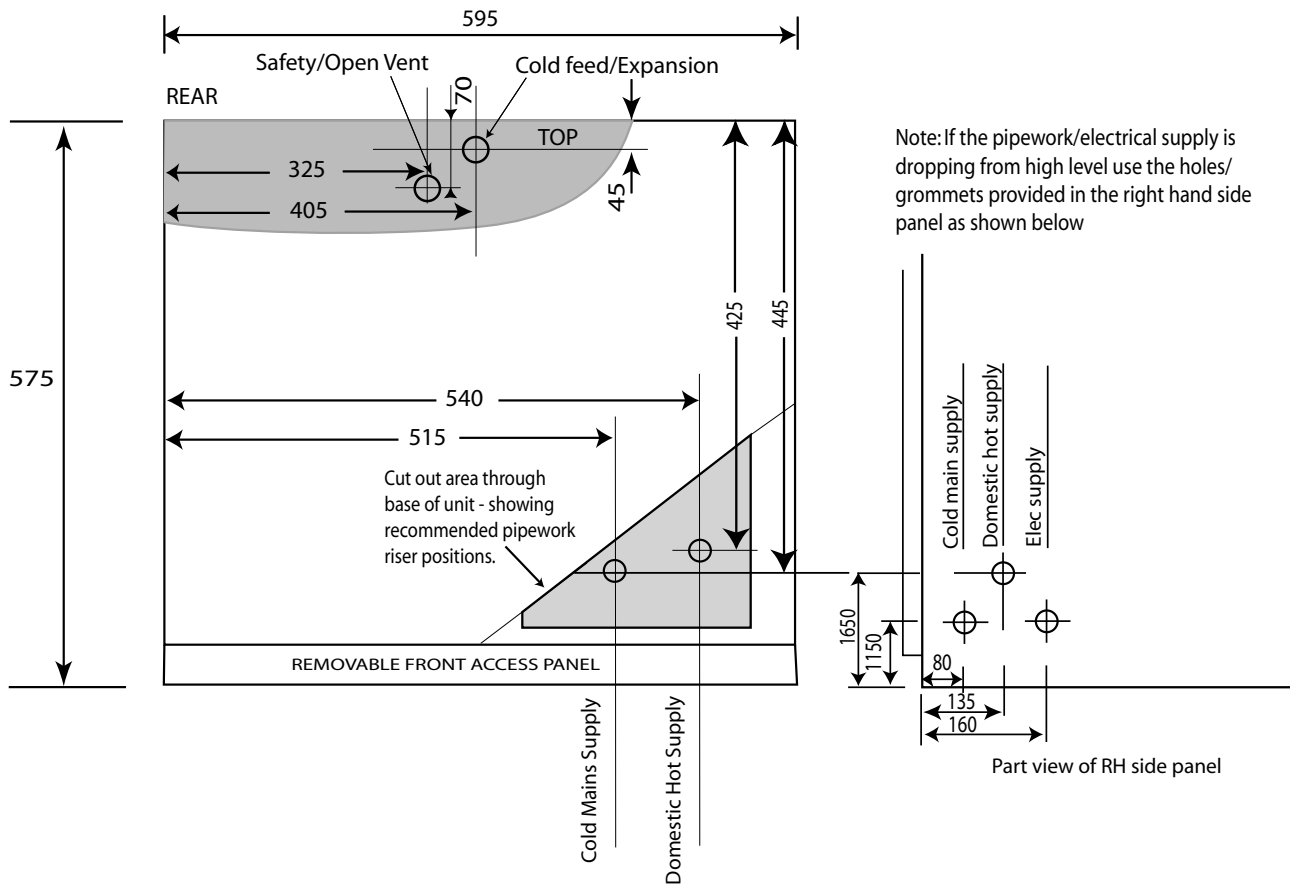

PLAN OF APPLIANCE CONNECTIONS

The Pulsacoil 2000 units are supplied on an installation base to allow the pipe runs to connect to the appliance from any direction. It is easier if all pipes protrude vertically in the cut out area shown. Compression or push fit connections can be used and we do offer a set of flexible connectors as an option. All pipe positions are approximate and subject to a tolerance of +/- 10mm in any direction. Space will also be required for a 15mm cold water supply and a 22mm warning / overflow pipe (if provided) for the separate feed and expansion cistern.

If a warning/overflow pipe is NOT provided the F&E Cistern should be filled from a temporary hose connection incorporating a double check valve. This can be from a temporary hose connection supplied from a cold water tap or a permanent cold branch provided adjacent to the F&E Cistern. The temporary connection must be removed once the appliance is filled.

1.3 SYSTEM DETAILS

Hot and Cold Water System

General

A schematic layout of the hot and cold water services in a typical small dwelling is shown below. Pulsacoil 2000 will operate at mains pressures as low as 1 bar and as high as 5 bar although the recommended range is 2-3 bar. If the manifolds (available as an optional extra) are being used the inlet pressure to the manifold must be a minimum of 2 bar. It is also important to check that all other equipment and components in the hot and cold water system are capable of accepting the mains pressure available to the property. If the mains pressure can rise above 5 bar or the maximum working pressure of any item of equipment or component to be fitted in the system, a pressure limiting (reducing) valve set to 3 bar will be required.

Note : Each Pulsacoil 2000 is fitted with a strainer and flow regulator on the cold mains supply connection. If the supply pressure is less than 2 bar or if the manifolds (available as an optional extra) are being used or if all taps are provided with flow regulators the flow regulator on the cold inlet should be removed.

No check valve or similar device should be fitted on the cold water supply branch to the Pulsacoil 2000.

Because of the innovative method of hot water production no scale reducer is required on the branch to the appliance. However, to comply with the Benchmark Guidance Note for Water Treatment in Heating and Hot Water Systems the installer should check the hardness level of the water supply and if necessary fit a scale reducer to provide protection to the whole of the domestic water system.

The hot water flow rate from the Pulsacoil 2000 is directly related to the adequacy of the cold water supply to the dwelling. This must be capable of providing for those services, which could be required to be supplied simultaneously, and this maximum demand should be calculated using procedures defined in BS 6700.

If a water meter is fitted in the service pipe, it should have a nominal rating to match the maximum hot and cold water peak demands calculated in accordance with BS 6700. This could be up to 60ltr/min in some properties.

Note: The diagram below shows the F & E cistern with ball valve and warning/overflow pipe which can be fitted if required. However, the standard preferred arrangement is for the cistern to be manually filled from a temporary hose connection fitted with a double check valve.

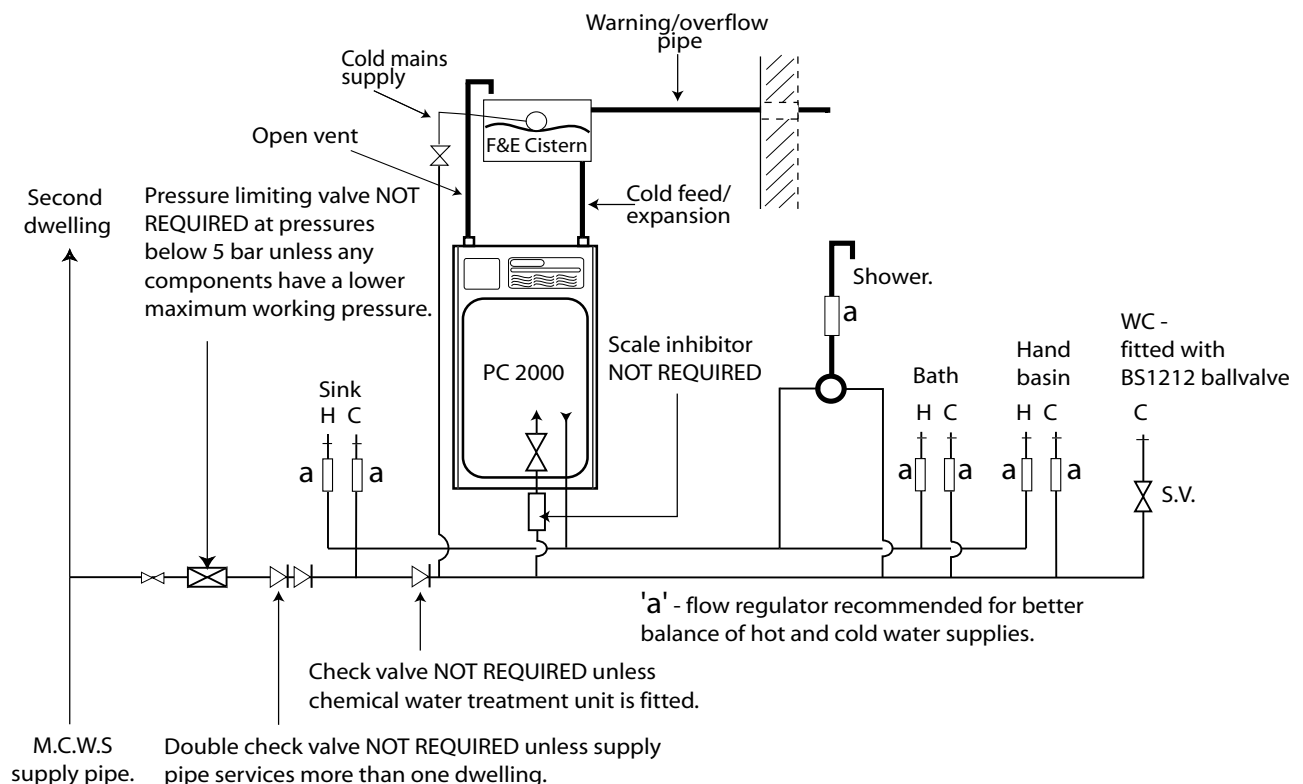

Typical hot and cold water distribution

1.3 SYSTEM DETAILS

Hot and Cold Water System

Pipe Sizing / Materials

To achieve even distribution of the available supply of hot and cold water, it is important in any mains pressure system, that the piping in a dwelling should be sized in accordance with BS 6700. This is particularly important in a large property with more than one bathroom.

However, the following rule of thumb guide lines should be adequate for most smaller property types as long as water pressures are within the recommended range of 2-3 bar.

1. A 15mm copper or equivalent external service may be sufficient for a small 1bathroom dwelling (depending upon the flow rate available), but the minimum recommended size for new dwellings is 22mm (25mm MDPE).
2. The internal cold feed from the main incoming stop tap to the PulsaCoil should be run in 22mm pipe. The cold main and hot draw-off should also be run in 22mm as far as the branch to the bath tap.
3. The final branches to the hand basins and sinks should be in 10mm and to the baths and showers in 15mm. (1 metre minimum)
4. **We would recommend that best results for a balanced system are achieved by fitting appropriate flow regulators to each hot and cold outlet. These MUST be fitted in cases where the final branch pipe sizes are not as recommended in item 3 or water pressures are above the recommended water pressure range of 2-3 bar. Details of suitable flow regulators are provided in Appendix A.**

Note: If manifolds (available as an optional extra) are being used suitable flow regulators are automatically provided in the manifold and do not need to be provided at each outlet. See Appendix B for further details.

All the recommendations with regard to pipework systems in this manual are generally based on the use of BS/EN Standard copper pipework and fittings.

However, we are happy that plastic pipework systems can be used in place of copper internally as long as the chosen system is recommended for use on domestic hot and cold water systems by the manufacturer and is installed fully in accordance with their recommendations.

This is particularly important in relation to use of push fit connections when using the optional flexible hose kits - see 2.2 Installation, Pipework connections.

It is also essential that if an alternative pipework material/system is chosen the manufacturer confirms that the design criteria of the new system is at least equivalent to the use of BS/EN Standard copper pipework and fittings.

Taps/Shower Fittings

Aerated taps are recommended to prevent splashing.

Any type of shower mixing valve can be used as long as both the hot and cold supplies are mains fed. However all mains pressure systems are subject to dynamic changes particularly when other hot and cold taps/showers are opened and closed. To minimise the impact of this we would always recommend the use of thermostatic showers with this appliance.

The shower head provided must also be suitable for mains pressure supplies.

However, if it is proposed to use a 'whole body' or similar shower with a number of high flow/pressure outlets please discuss with the Gledhill technical department.

The hot water supply to a shower-mixing valve should be fed wherever practical directly from the PulsaCoil 2000 or be the first draw-off point on the hot circuit. The cold supply to a shower-mixing valve should wherever practical be fed directly from the

rising mains via an independent branch. The shower must incorporate or be fitted with the necessary check valves to provide back-syphonage protection in accordance with the Water Regulations.

The supply of hot and cold mains water directly to a bidet is permitted provided that it is of the over-rim flushing type and that a type 'A' air gap is incorporated.

Hot and Cold Water System

If the length of the hot water draw off pipework is excessive and the delivery time will be more than 60 seconds before hot water is available at the tap, you may wish to consider using trace heating to the hot water pipework such as the Raychem HWAT system. Please consult Gledhill Technical Department for further details.

Note: A conventional pumped secondary circulation system is **NOT** suitable for use with this appliance.

It is important that the cold water pipework is adequately separated/protected from any heating/hot water pipework to ensure that the water remains cold and of drinking water quality.

1.0 DESIGN

1.3 SYSTEM DETAILS

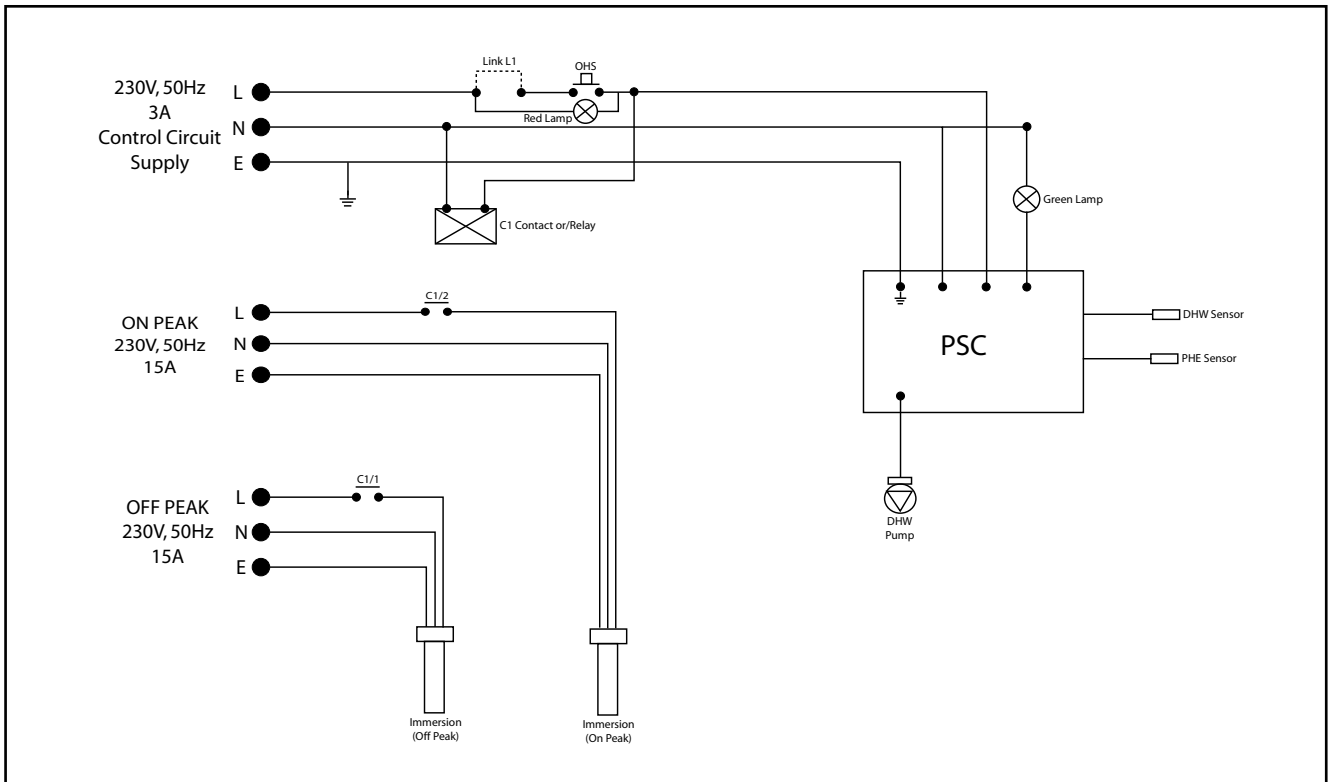

PulsaCoil 2000 Schematic Wiring Diagram

Electrical Installation

The Schematic arrangement of the wiring within the PulsaCoil 2000 is shown above.

The whole of the electrical installation shall be designed and installed by a competent person fully in accordance with the latest edition of the Requirements for Electrical installations BS 7671.

The PulsaCoil 2000 appliance is provided with two side entry 3kW immersion heaters and has been designed to generally operate with an off peak supply.

The lower immersion heater heats the whole of the contents and is normally connected to the off peak supply.

1.0 DESIGN

1.3 SYSTEM DETAILS

Electrical Installation

The upper immersion heater is positioned at a level on the PulsaCoil 2000 to provide sufficient hot water for at least one bath - see Technical Data Table on page 5. This is connected to the unrestricted on peak supply and is normally switched manually by the householder to provide a day time boost when required. Alternatively a time clock could be wired into this supply to provide an automatic boost on a daily basis if preferred.

NOTE: The PC 125 model is only supplied with a lower immersion heater.

The size of the appliance and the need to use the on peak boost facility is reduced if a better off peak tariff can be agreed with the electrical supply company - see Model Selection Guide on page 5.

A 3 amp supply is also required from the unrestricted on peak supply for the control circuit.

Although the PulsaCoil 2000 appliance is primarily designed to operate with an off peak supply it will also operate quite successfully if it is only supplied with an on peak supply. However, this will substantially increase the running costs of the appliance and should only be considered if an off peak supply is not available.

Two typical methods of providing electrical supplies are shown below for information. However, the PulsaCoil 2000 appliance is suitable for use with any method of supply - if unsure please consult Gledhill Technical Department for further assistance.

If separate circuits are provided the two switches must be clearly labelled for the householders use.

Note:
In addition to the supplies to the immersion heaters, PulsaCoil 2000 requires a 3 amp supply for the control circuit. This 3 amp supply must be provided via a fused 3 amp double pole isolator providing 3mm of separation to both poles.

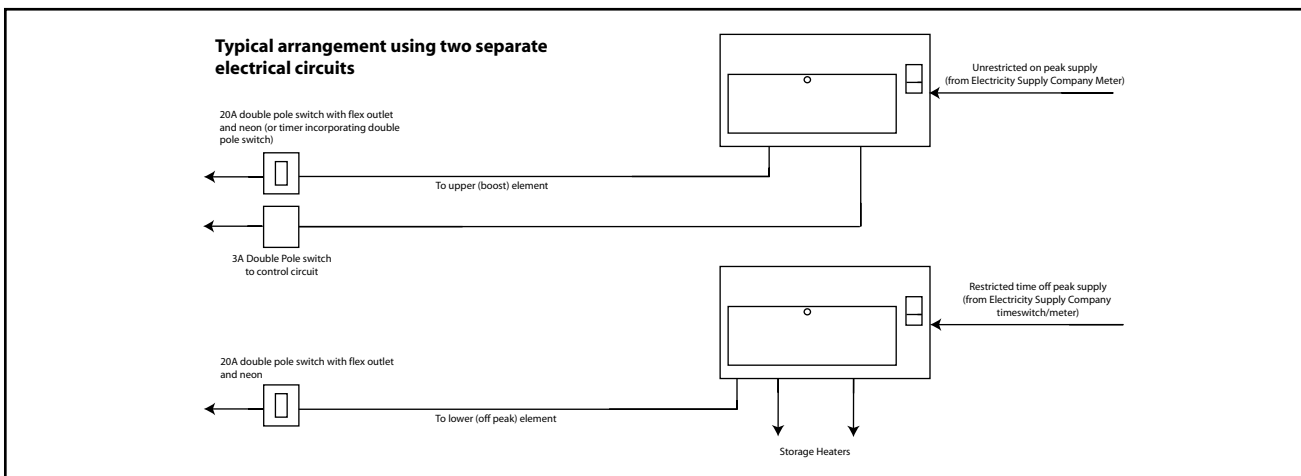
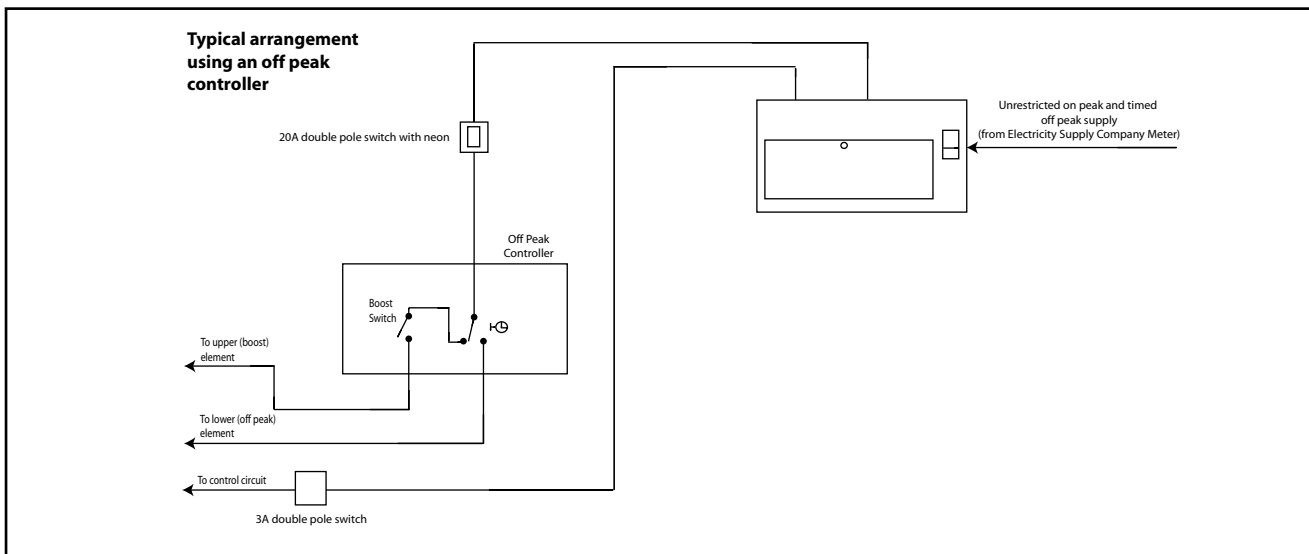

2.1 SITE REQUIREMENTS

The appliance is designed to be installed in an airing/cylinder cupboard and the relevant minimum dimensions are provided in section 1.2 Technical Data.

Because of the ease of installation we recommend that the cupboard construction is completed and painted before installation of the appliance. The cupboard door can be fitted after installation.

If the unit needs to be stored prior to installation it should be stored upright in a dry environment and on a level base/floor.

Installation and maintenance access is needed to the front of the appliance and above the F & E cistern. See Section 1.2 Technical Data for further details.

The minimum dimensions contained in section 1.2 Technical Data allow for the passage/connection of pipes to the appliance from any direction as long as the appliance is installed on the installation base provided. If the installation base is not used extra space may be needed to allow connection to the pipework and the whole of the base area should be continuously supported on a material which will not easily deteriorate if exposed to moisture.

The floor of the cupboard needs to be level and even and capable of supporting the weight of the appliance when full. Details of the weight when full is provided in section 1.2 Technical Data.

The appliance is designed to operate as quietly as practicable. However, some noise (from pumps etc) is inevitable when hot water is being used. This will be most noticeable if the cupboards are located adjacent to bedrooms, on bulkheads, or at the mid span of a suspended floor.

Cupboard temperatures will normally be higher than in a conventional system and the design of the cupboard and door will need to take this into account. No ventilation is normally required to the cupboard.

The separate feed and expansion cistern will need to be located on top of the appliance or at high level in the cupboard housing the PulsaCoil 2000. The dimensions and clearances are provided in section 1.2 Technical Data. The location will need to provide a suitable route for the cold feed and expansion pipe as well as the open safety vent pipe. The location will also need to provide a suitable route and discharge position for the warning/overflow pipe and the ballvalve supply from the mains cold water system (if provided).

Note: The standard appliance is supplied with a cistern without a ballvalve/overflow for filling manually.

An electrical supply must be available which is correctly earthed, polarized and in accordance with the latest edition of the IEE requirements for electrical Installations BS 7671.

The electrical mains supply needs to be 230V/50Hz.

The sizes/types of electrical supplies must be as detailed in 1.3 System Details, Electrical Installation and the connections must be made using a double-pole linked isolator with a contact separation of 3mm in both poles which are located within 1m of the appliance. The supplies must only serve the appliance.

The hot and cold water 'first fix' pipework should be terminated 50mm above the finished floor level in accordance with the dimensions provided in 1.2 Technical Data.

2.2 INSTALLATION

Before installation the site requirements should be checked and confirmed as acceptable.

The plastic cover and protective wrapping should be removed from the appliance and the installation base (provided) placed in position.

The appliance can then be lifted into position in the cupboard on top of the base and the front panel removed by unscrewing the 2 screws and lifting the door up and out, ready for connection of the pipework and electrical supplies.

The feed and expansion cistern support shall be installed ensuring that the base is fully supported, the working head of the appliance is not exceeded and the recommended access is provided for maintenance - see section 1.2 Technical Data for details.

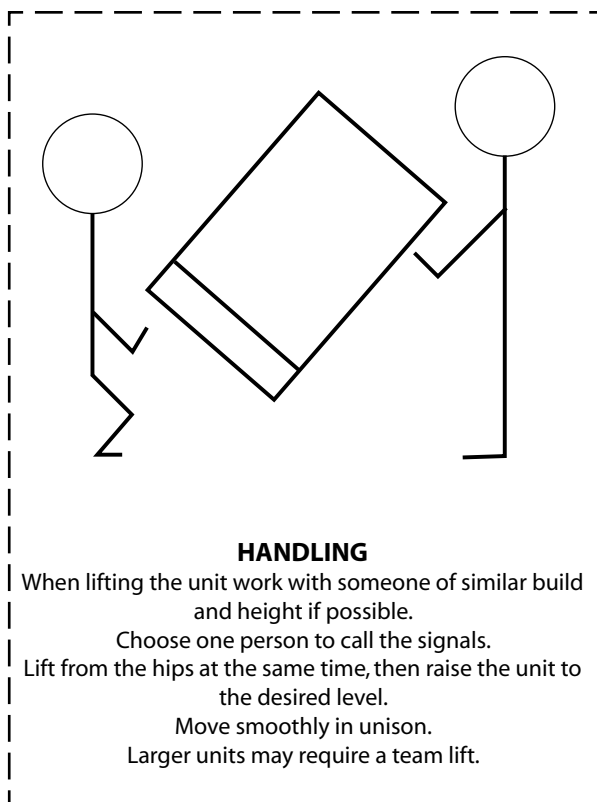

Preparation/placing the appliance in position.

The 'first fix' pipework positions should be checked using the template provided with each appliance. If these have been followed installation is very simple and much quicker than any other system.

The appliance is supplied shrink wrapped on a timber installation base. Carrying handles are also provided in the back of the casing.

The feed and expansion cistern complete with ballvalve, cold feed/expansion and overflow/warning pipe fittings are provided in a separate box.

If flexible connections have been ordered these will also be inside the feed and expansion cistern.

The appliance should be handled carefully to avoid damage and the recommended method is shown above.

Note: Although the above guidance is provided any manual handling/lifting operations will need to comply with the requirements of the Manual Handling Operations Regulations issued by the H.S.E.

The appliance can be moved using a sack truck on the rear face although care should be taken and the route should be even.

In apartment buildings containing a number of storeys we would recommend that the appliances are moved vertically in a mechanical lift.

If it is proposed to use a crane expert advice should be obtained regarding the need for slings, lifting beams etc.

2.2 INSTALLATION

Pipework connections

The position of the pipework connections is shown opposite. The connection sizes and dimensions are listed in Section 1.2 Technical Data.

All the connections are also labelled on the appliance. It is essential that the pipework is connected to the correct connection.

The connections can be hard piped but we recommend the use of flexible connections (available as an optional extra).

If using push fit connectors with the flexible hose kits it is important to check that they are compatible. Written approval has already been obtained for:-

Hepworth - Hep₂O BiTite
John Guest - Speedfit
Yorkshire - Tectite

However, as similar assurances cannot be obtained for Polypipe fittings we cannot recommend their use.

Connections A, B and D are plain ended copper pipe.

Connection C is a compression fitting.

Connection E is RC $\frac{1}{2}$ ($\frac{1}{2}$ in BSPT internal)

- A - Safety open vent
- B - Cold feed/expansion
- C - Incoming mains cold water
- D - Domestic hot water
- E - Drain tap connection

Note: The safety open vent and cold feed/expansion should be connected to the F & E cistern using the pipework assembly provided.

All factory made joints should be checked after installation in case they have been loosened during transit.

The fittings for the feed and expansion cistern should be installed following the instructions provided by the manufacturer in a position to suit the particular location and the cistern fitted on its supports/base.

The cold feed/expansion and safety open vent should be installed between the appliance and the feed and expansion cistern.

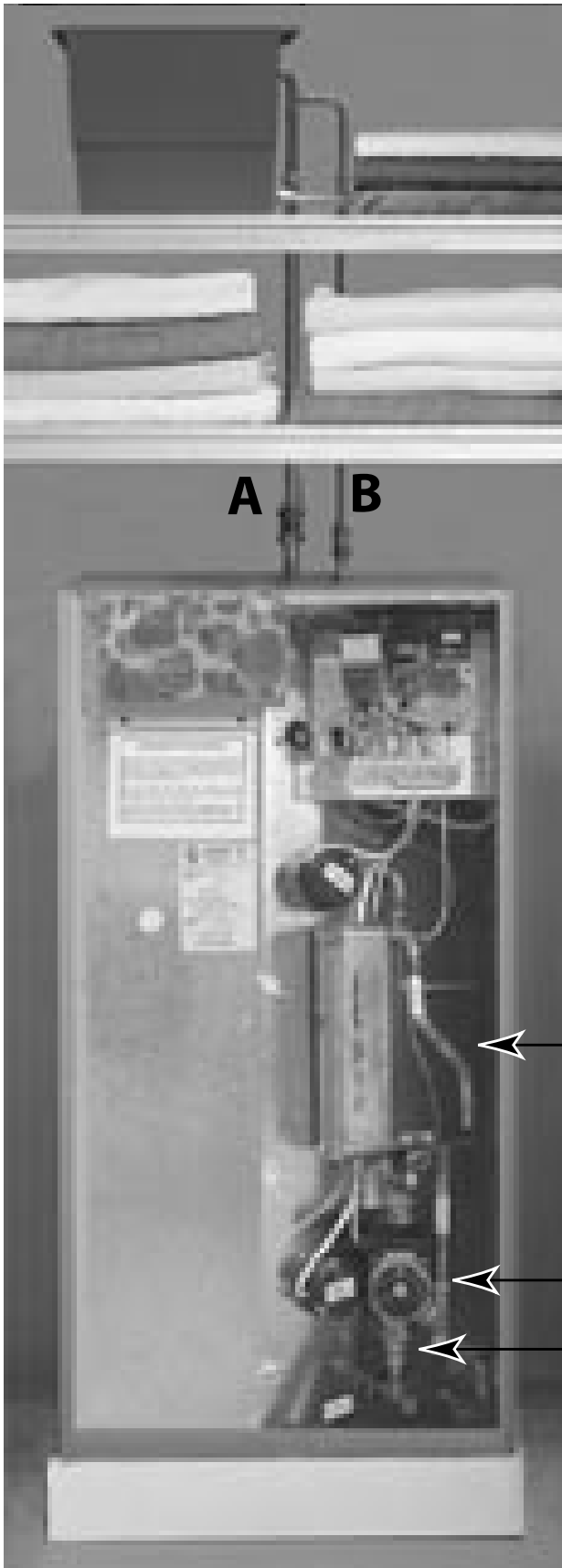

2.0 INSTALLATION

2.2 INSTALLATION

It is normally envisaged that the feed and expansion cistern will be located in the same cupboard as the PulsaCoil 2000 appliance itself to maintain a dry roof space.

The cold feed/open vent pipework assembly (as supplied) should be used if it is intended to install the F & E cistern directly on top of the appliance.

However, if it is necessary to locate the cistern in the roof space (or on a higher floor) the cold feed/open vent pipework assembly (as supplied) should be used to connect to the F & E cistern and pipework site run by the installer to connect this to the appliance.

Obviously, any pipework in the roof space and the feed and expansion cistern will need to be adequately insulated to protect against frost damage.

Combined feed and open vent pipe arrangements must not be used.

No valves should be fitted in the safety open vent which must be a minimum of 22mm copper pipe or equivalent.

The mains cold water supply to the ballvalve shall be provided with a suitable servicing valve.

The overflow/warning pipe (if provided) shall have a continuous fall, be fitted to discharge clear of the building and be sited so that any overflow can be easily observed. It shall also be installed in a size and material suitable for use with heating feed and expansion cisterns in accordance with BS 5449 (e.g 22mm copper) and should not have any other connections to it.

Note: If a warning/overflow pipe is NOT provided the F & E cistern should be filled from a temporary hose connection supplied from any cold water tap or from a permanent cold branch provided adjacent to the F & E cistern. The temporary hose must be fitted with a double check valve and removed once the appliance is filled.

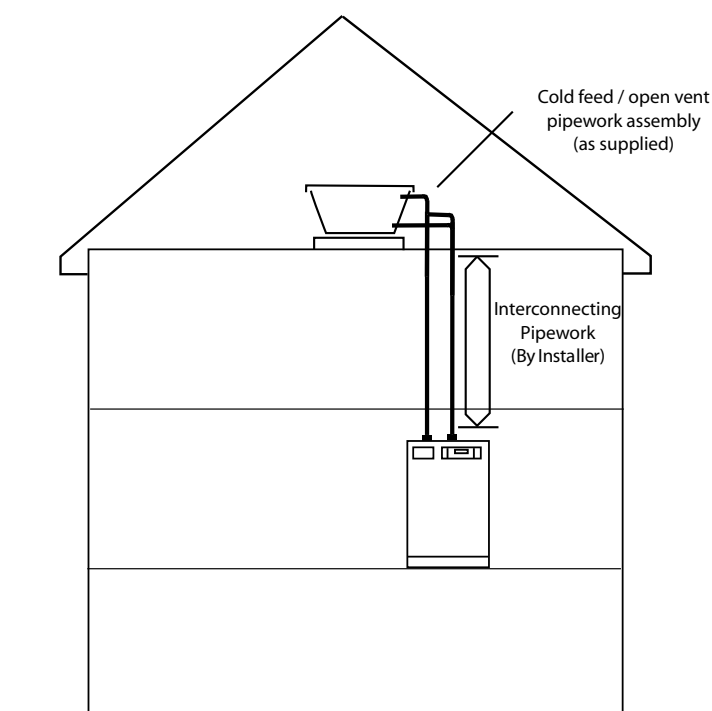

2.0 INSTALLATION

2.2 INSTALLATION

WIRING DIAGRAM - STANDARD PULSACOIL 2000 APPLIANCE

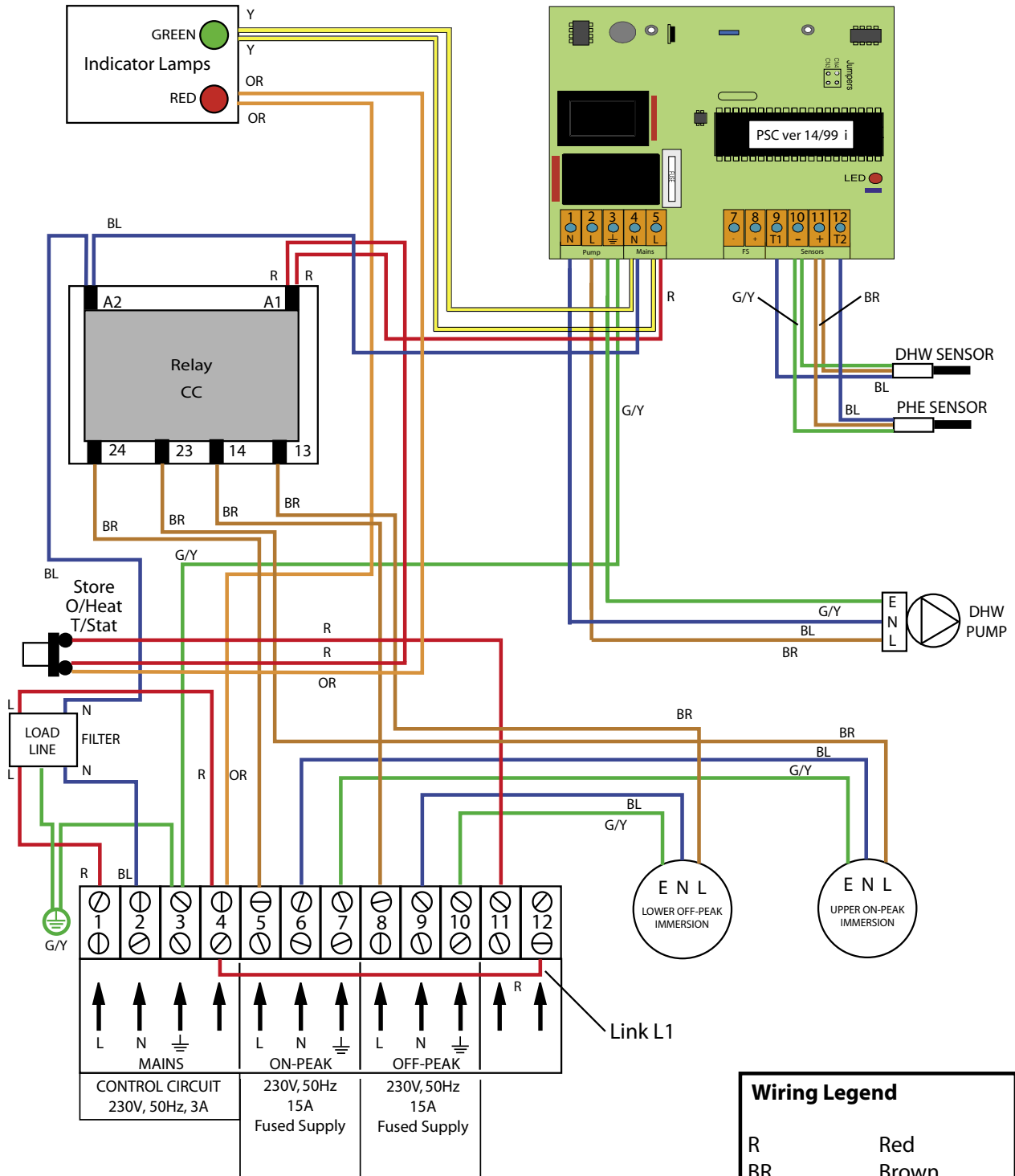

NOTE : Link L1 should only be moved from terminal 12 to terminal 11 after the appliance has been commissioned as per page 19.

The PC 125 model is only provided with the lower (Off Peak), immersion heater.

PULSACOIL 2000

| | |
|--------------|-----------------|
| ISSUE NO : 6 | DATE : DEC 2002 |
| APPROVED | |

2.0 INSTALLATION

2.2 INSTALLATION

Electrical Connection - Standard Appliance

The PulsaCoil 2000 is pre-wired to a 12 way terminal strip from the A.C.B. and plumbers are well able to complete the electrical installation as long as they are competent to carry out the work strictly in accordance with the IEE Requirements for Electrical Installations BS 7671. The arrangement of the wiring is shown on the previous page.

All the terminals are suitably labelled.

Note: Do not attempt the electrical work unless you are competent to carry it out to the above standards.

Before commencing check that the power source is in accordance with section 2.1 Site Requirements and ensure that it is isolated.

Run the external wiring from the adjacent isolator through the service slot provided in the base of the appliance.

Make the connections as shown opposite on the terminal strip provided.

Clamp the cables in the grips provided below the terminal strip and ensure all cables are routed to avoid hot surfaces.

Note: The appliance pipework should be bonded to earth to comply with the IEE Requirements for Electrical Installations BS 7671.

The appliance is provided with a 4.0mm earth cable from a strap on the case to the earth stud on the wiring panel.

Before switching on the electrical supply check all the factory made terminal connections to ensure they have not become loose during transit.

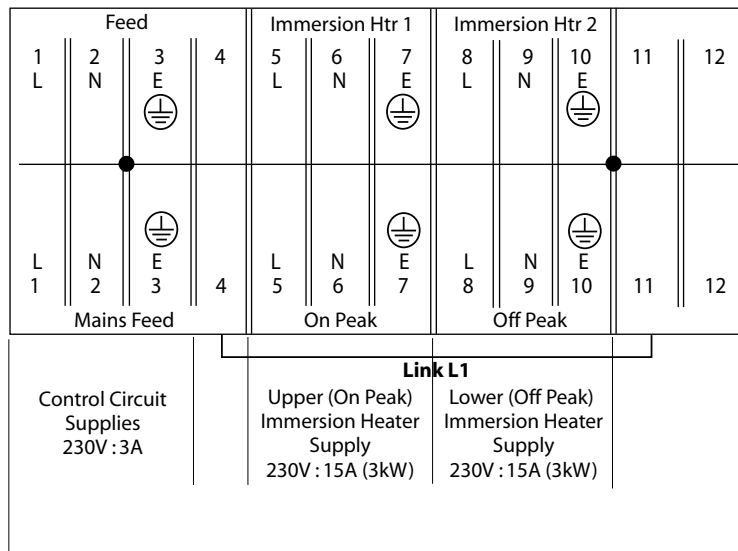

NOTE: The three 230V, 50Hz supplies should be as shown in the schematic diagram on page 12.

The PC 125 model is only supplied with the lower (off peak) immersion heater.

2.3 COMMISSIONING

Open the incoming stop valve and fill the domestic mains cold and hot water systems including the PulsaCoil 2000 appliance.

Check the water level in the feed and expansion cistern and if a ballvalve is fitted adjust if necessary.

Check the whole of the domestic hot and cold distribution systems for leaks.

2.3 COMMISSIONING

Fully flush and if necessary chlorinate the hot and cold water system in accordance with the recommendations in the Water Regulations and BS 6700.

Once the system is finally filled turn down the servicing valve for the ballvalve in the F & E cistern to the point where the warning/overflow pipe will cope with the discharge arising from a ballvalve failure.

If an overflow is not provided ensure the temporary filling hose is isolated and removed from its connection to the cold water supply.

It is essential that all systems function properly for optimum performance.

To achieve this the flow rate from each tap should be checked and a suitable number of taps run simultaneously to check the impact of this on the flow rate at individual taps.

We recommend that flow restrictors are provided for each tap/terminal fitting to ensure that the available flow is shared evenly - See Appendix A for further details.

Commissioning the PulsaCoil Control System

Once the PulsaCoil 2000 is filled with water one end of the link (L1) can be removed from terminal 12, inserted into terminal 11, and the electrical supplies switched on.

WARNING - Inserting this link into terminal 11 will complete the electrical control circuit and allow a supply to the immersion heaters. DO NOT INSERT THIS LINK AND SWITCH ON THE ELECTRICITY SUPPLY UNTIL YOU HAVE CHECKED THAT THERE IS WATER IN THE F & E CISTERN . Failure to do this will result in dry firing and premature failure of the immersion heaters.

The green indicating lamp on the front of the appliance will light to show the control circuit supply is live.

The red indicating lamp will only light to indicate a fault condition, (See 3.4 Fault Finding for further details).

Note: It will light initially if the electricity is switched on and the link has not been moved from terminal 12 to terminal 11.

When the green indicating lamp is lit switch on the on-peak (top) immersion heater and allow the appliance to reach temperature. Check that the rod thermostat mounted in the on peak immersion heater has switched off at the correct temperature of approx 72°C.

When this has been proven isolate the incoming power supplies and remove the incoming on and off peak supplies from the immersion heater supply terminals. Temporarily reconnect the on peak supplies to the off peak terminals (numbers 8, 9) and 10) and allow the appliance to reach temperature.

Check the rod thermostat has switched off the off peak immersion heater at the correct temperature of approx 72°C.

If the control thermostats do not switch off the immersion heaters at the correct temperature the overheat thermostat will operate the manual reset button. In this case check and adjust or replace the relevant rod thermostat and reset the overheat button. Reduce the store temperature by running some hot water and repeat the test relevant to the immersion heater/control thermostat concerned.

Once it has been proved that the control thermostats are working correctly isolate the incoming power supplies and re-connect the immersion heater supplies in accordance with the details in 2.2 Installation.

Run a tap and using a digital thermometer check that the temperature of the hot water is about 55°C. This temperature is factory set and is independent of the store temperature and hot water flow rates.

This product is covered by the 'Benchmark' scheme and a separate commissioning/ service log book is included with this product. This must be completed during commissioning and left with the product to meet the Warranty conditions offered by Gledhill.

Important Do's and Don'ts

1. **DO** check the incoming mains water pressure. The preferred range of mains pressure is 2 -3 bar.
2. **DO** check the flow rate of the incoming cold water main is adequate to meet the maximum hot and cold water simultaneous demands.
3. **DO** check that all connections are in accordance with the labelling on the thermal store.
4. **DO NOT** insert link (L1) and switch on the electricity supply until you have checked that the appliance is full of water i.e. there is water in the F & E cistern.
5. **DO** check the water level is correctly set in the F & E cistern when cold and that there is no overflow when the appliance is up to temperature.
6. **DO** check that the rod thermostats switch the immersion heaters on/off at the correct set points i.e. approx 72°C.
7. **DO** insulate any exposed hot water pipework in the PulsaCoil cupboard.
8. If the ballvalve in the F & E cistern is permanently connected to the mains cold water supply **DO** plumb the overflow/warning pipe in a 20mm internal diameter pipe and ensure it discharges in a conspicuous external position. Use a material which is suitable for use with heating F & E cisterns in accordance with BS 5449 (such as copper).
9. **DO** ensure the green light is 'on' and the red fault light is off.
10. **DO** ensure that the functioning and control of the system is explained to the occupant.

These instructions should be placed along with the component manufacturers instructions in the pocket provided on the rear of the front panel. The front panel should then be refitted.

3.0 SERVICING

3.1 ANNUAL SERVICING

No annual servicing of the PulsaCoil 2000 is necessary.

However, if required, the operation of the controls and a hot water performance test can be carried out to prove the appliance is working satisfactorily and within its specification.

3.2 CHANGING COMPONENTS

Free of charge replacements for any faulty components are available from Gledhill during the in-warranty period on return of the faulty part (normally 12 months).

After this, spares can be obtained direct from Gledhill using the 'Speed Spares' service, or through any of the larger plumbers merchants/specialist heating spares suppliers.

Help and advice is also available from the Technical Helpline on 01253 474401.

However, all components are readily accessible and can be changed quickly and easily by the installer using common plumbing practice.

If it is necessary to replace the pump fitted to the appliance the pump head (motor pack) only should be removed as recommended by Grundfos. Assuming it is within warranty this will be accepted by a merchant as being covered by the Grundfos national service exchange agreement, as long as it is a complete pump i.e. alleged faulty motor pack and new base is left with the merchant. It is important when a pump has been replaced to ensure that any air is adequately vented and the pump is set on speed 3.

3.0 SERVICING

3.3 SHORT PARTS LIST

| Key No. | Description | Manufacturer | Stock Code No. | Gas Council Part No. |
|---------|---------------------------------------|-------------------|----------------|----------------------|
| 1 | Feed and expansion cistern | Polytank | XB366 | - |
| 2 | Ball float | Masfield/Epson | FT429 | 370 506 |
| 3 | Ballvalve | Beta | FT207 | 370 505 |
| 4 | Single check valve | Detail Plastic Co | GT048 | E37 479 |
| 4 | Brass housing | Midland Brass Co | GT049 | - |
| 5 | 15/50 pump with 1½" connections | Grundfos | XB001 | 384 288 |
| 6 | 22mm ball type pump valve | Vemco | XB121 | E26 010 |
| 7 | Plate heat exchanger | Swep | GT017 | E05 664 |
| 8 | Pump Speed Control board (P.S.C) | Elok | GT152 | E26 023 |
| 9 | Rod Thermostat (for immersion heater) | Diamond | XB003 | - |
| 10 | PHE return sensor | Elok | GT146 | E26 024 |
| 11 | D.H.W. temperature sensor | Elok | GT153 | E26 024 |
| 12 | Power relay | Omron | XB298 | E39 163 |
| 13 | 20mm high break fuse 1 amp | | - | - |
| 14 | Overheat Thermostat | Ranco | GT064 | - |
| 15 | 'Y' Type strainer | | XB314 | - |
| 16 | Flow regulator | | GT086 | - |
| 17 | Immersion Heater | Shell | XB077 | - |
| 18 | Electronic Noise Filter | Schaffner | XB307 | - |

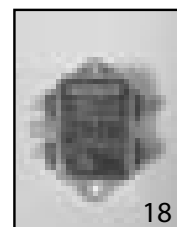
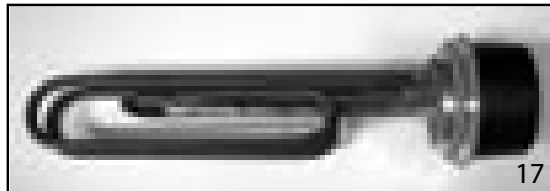
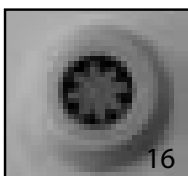
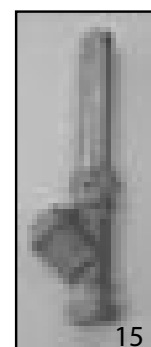
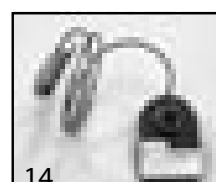
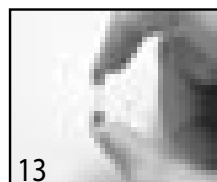
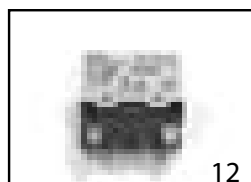
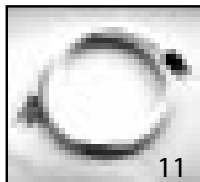
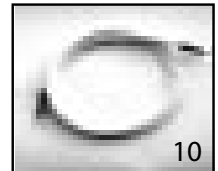
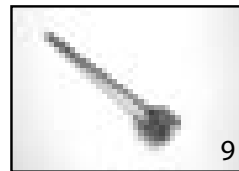
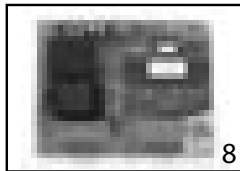
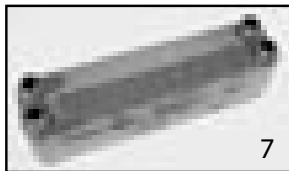
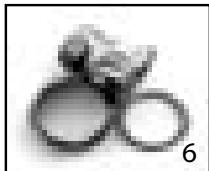
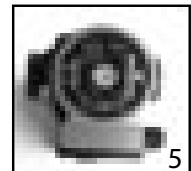
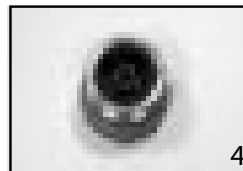
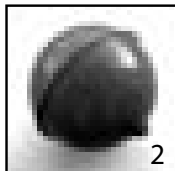
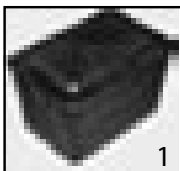

3.4 FAULT FINDING

Despite everyone's best efforts some problems can occur and lead to complaints from the householder.

The following checks should be carried out by the installer before calling the manufacturer.

1. Noise when hot water tap is opened/closed

If the plate heat exchanger pump is noisy when the hot water tap is opened, then check the level of water in the F & E cistern and vent the pump if necessary.
Water hammer - loose pipework and/or tap washers.

2. Causes of 'Unsatisfactory Hot Water Service'

| FAULT CONDITION | POSSIBLE CAUSES |
|--|--|
| DHW temperature remains cold exiting the taps. | <ul style="list-style-type: none"> - Thermal store is cold/DHW pump is stuck - Temperature sensor or pump speed control PCB is faulty - Too little or too much flow from the pipe - The water level is low in the F&E cistern. - Overheat stat tripped/fault lamp on. |
| DHW temperature fluctuates wildly when flow is steady. | DHW pump keeps sticking when voltage is reduced and not starting until voltage is too high. |
| DHW temperature exceeds and remains well above 60°C when the flow rate is low. | <ul style="list-style-type: none"> - DHW pump speed control PCB and/or temperature sensor is/are faulty. - Immersion heater thermostat temperature setting too high should be 72°C. |
| Store not heating | <ul style="list-style-type: none"> - Link 'L1' is not correct - i.e. unit is not commissioned. - No power supplies to control circuit and heaters - Overheat stat has tripped/fault light on - Power relay faulty |

3. Overflow from Feed and Expansion Cistern

Check that the controlled level of water in the cistern is no higher than necessary. Adjust if required or check the ballvalve is shutting off the water supply.

4. Operation of the red indicating lamp on the front of the appliance.

This will light to indicate a fault condition. Initially this may be due to a failure to move one end of the link (L1) from Terminal 12 to Terminal 11.

However, once the unit is in use it will indicate an overheat condition and the manual overheat button will have popped out. If this is the case check and replace as necessary the relevant immersion heater thermostat (set to 75°C).

Manually reset the appliance by pressing in the manual overheat button (inside the appliance front cover).

3.0 SERVICING

3.4 FAULT FINDING

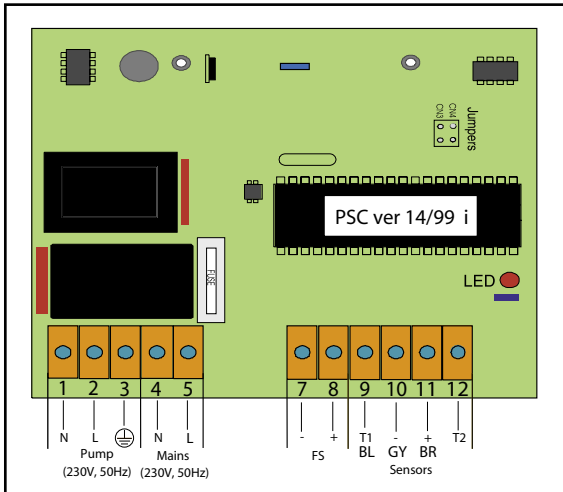

A number of the DHW faults indicated in the above chart will be indicated by the pump speed control PCB.

The layout of the pump speed control board is shown opposite. In faulty conditions if the hot water outlet temperature exceeds 60°, the pump speed will be reduced to minimum and if the outlet temperature exceeds 65°C, the pump will be switched off until the outlet temperature reduces to 50°C.

If hot water has not been used for a period of 30 hours the pump speed control board will run the pump for approximately 3 seconds to help prevent it sticking.

The red LED on the pump speed control board will also flash differently to indicate a number of fault conditions - see diagram opposite. If necessary change the faulty sensor (fault 2,3, or 4) board (fault 5) or fuse/check electrics (fault 6) to resolve the problem.

If the problem cannot be resolved by the installer the manufacturer should be contacted.

When requiring a visit from the manufacturer the installer must have the completed 'Benchmark' commissioning/service record sheet to hand to enable help to be provided.

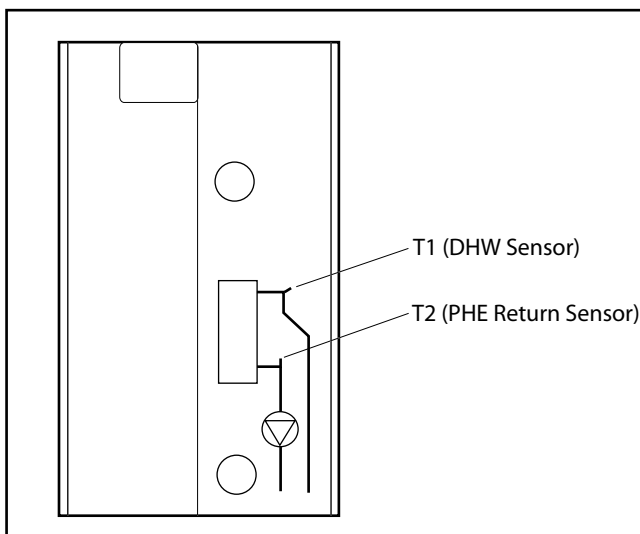
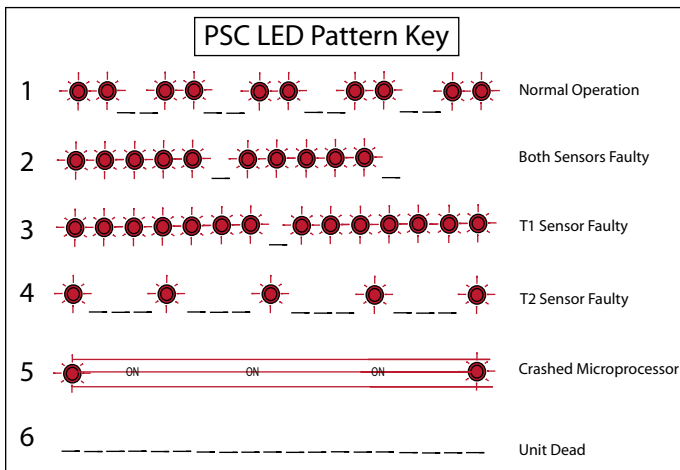

WATER SAVINGS

WATER RELATED COSTS CAN BE REDUCED BY GOOD PLUMBING PRACTICE.

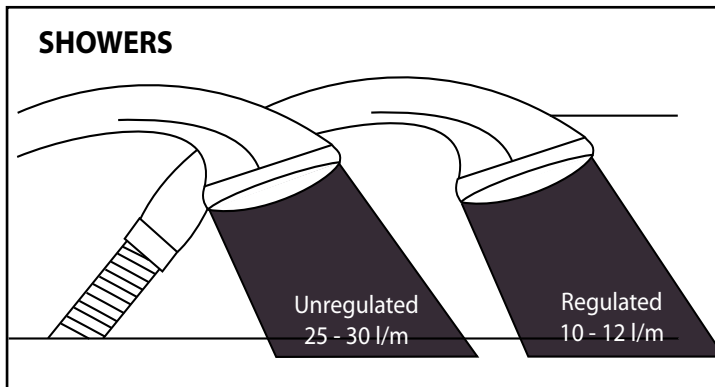
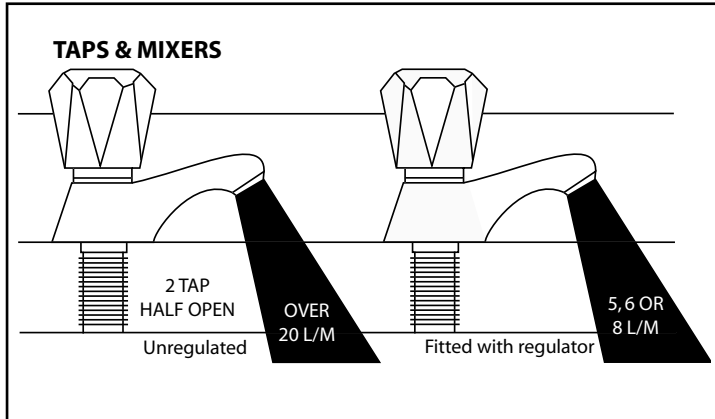

Vast quantities of water are needlessly run off to waste due to Taps, Mixers and Showers discharging flow rates far in excess of the rates required for them to perform their duties.

The contrasting flow rates shown on this leaflet clearly illustrate the savings that can be made whilst still providing a good performance.

British made Aquaflow Regulators provide constant flow rates by automatically compensating for supply pressure changes between 1 bar & 10 bars.

To facilitate installation into the wide range of plumbing equipment which is encountered in the U.K, Four Fixing Options are available:-

OPTIONS FOR SHOWERS

1. MXF "DW" Range - For fitting behind Fixed Shower Heads or onto Flexible Hoses for Handshowers (preferably onto the inlet end when lightweight hoses are used).
2. Compression Fitting Range. "In Line" regulators as in Option 4 for Taps & Mixers.

Information by courtesy of

AQUAFLOW REGULATORS LTD

Haywood House, 40 New Road, Stourbridge, West Midlands DY8 1PA
TELEPHONE (01384) 442611 FAX: (01384) 442612

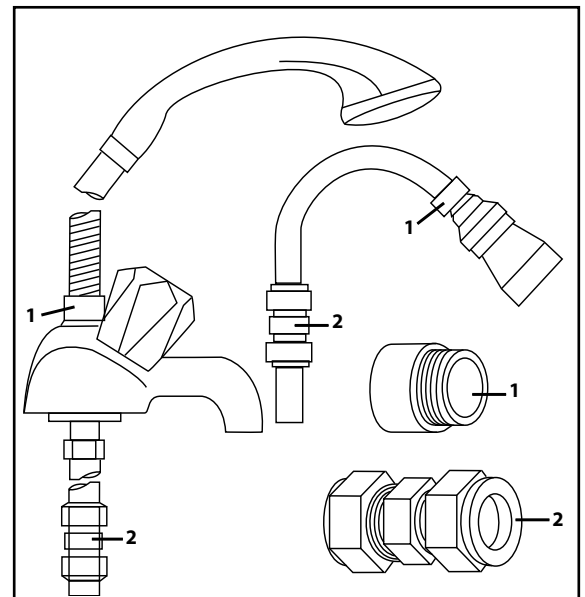

4 FIXING OPTIONS FOR TAPS & MIXERS

1. MK Range - Combined Regulators & Aerator for screwing onto Taps & Mixers with internal or external threads on their noses. Anti Vandal models also available.
2. MR05-T Range - Internal Regulators. Push-fit into Tap or Mixer seats. Produced in three sizes - 12.5mm (BS1010), 12mm & 10mm, Flangeless models also available for Taps with Low Lift washers.
3. MXF Standard Range - Screw on tail models for Taps & Mixers. Fix onto the tails before fitting the tap connectors. Available in 3/8", 1/2", 3/4" and 1" BSP.
4. Compression Fitting Range - "In Line" regulators housed in 15mm & 22mm CXC Couplers & Isolating Valves. ^{UNIVERSITY} ~~UNIVERSITY~~ by the Water Research Centre. Isolation valves available for slotted screwdriver operation or with coloured plastic handles. Now available also in plastic bodied push-fit couplers & valves.

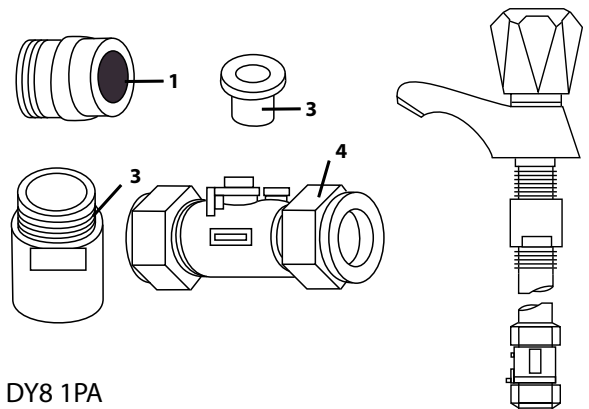

APPENDIX B

MANIFOLDS

| Manifold type: 1 - Stock Code MIP 050 (one bathroom, one en suite shower room, one cloakroom) | | | |
|--|------------------|-------------------------------------|--------------------------------------|
| Flow regulator (litres/minute) | Terminal fitting | Hot water manifold outlets Quantity | Cold water manifold outlets Quantity |
| 18 | Bath tap | 1 | 1 |
| 8 | Hand basin | 3 | 3 |
| 10 | Kitchen sink | 1 | 1 |
| 8 | Toilet cistern | None | 3 |
| 8 | Shower | 1 | 1 |
| 8 | Washing machine | 1 | 1 |
| 8 | Dishwasher | None | 1 |
| Total | | 7 | 11 |

Two sets of manifolds are available as an optional extra. Each set comprises a separate hot and cold water manifold. Both are provided with a 22mm inlet connection located centrally. All outlet connections are 15mm compression. The centre to centre dimension of each branch is 55mm.

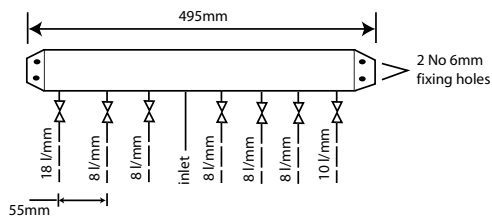

A

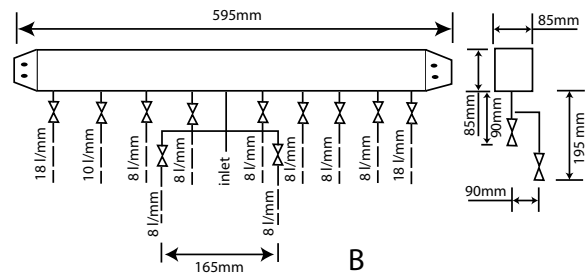

B

| Manifold type: 2 - Stock Code MIP 060 (two bathrooms, one en suite shower room, one cloakroom, one utility room) | | | |
|---|------------------|-------------------------------------|--------------------------------------|
| Flow regulator (litres/minute) | Terminal fitting | Hot water manifold outlets Quantity | Cold water manifold outlets Quantity |
| 18 | Bath tap | 2 | 2 |
| 8 | Hand basin | 3 | 3 |
| 10 | Kitchen sink | 2 | 2 |
| 8 | Toilet cistern | None | 3 |
| 8 | Shower | 1 | 1 |
| 8 | Washing machine | 1 | 1 |
| 8 | Dishwasher | None | 1 |
| Total | | 9 | 13 |

The arrangement of each manifold is supplied as shown. This provides the best balance of flows but the flow regulators/duty of each branch can be changed if required as long as a reasonable balance is maintained. If it is necessary to change or clean the flow regulator this can be done without needing to drain the system by closing the valve and removing the screwed cover below the white plastic cover.

The manifolds are designed to be used with plastic pipework and are supplied complete with isolation valves and flow regulators on each branch. They would normally be installed in the same cupboard as the thermal storage appliance (as shown on page 36) but can be installed in another cupboard close to the appliance if required.

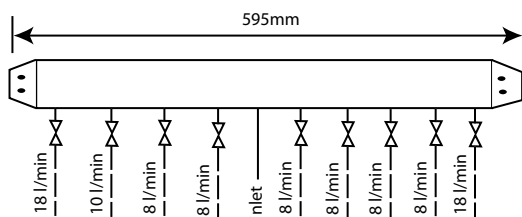

C

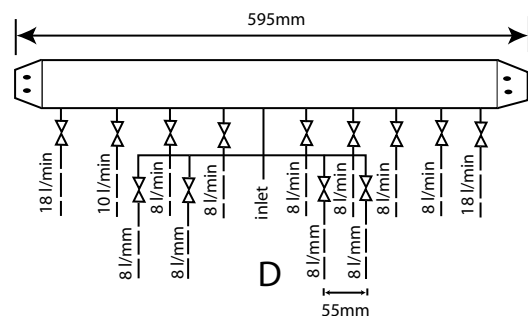

D

APPENDIX B

An optional location where cupboard space is tight



The pressure loss through a flow regulator at the designated flow rate is about 1.8 bar. Therefore for the flow regulator to control the flow rate at pre-set level, the inlet pressure must be greater than 1.8 bar. If the inlet pressure is lower, the flow rate will be correspondingly less than the pre-set values.

The maximum equivalent pipe lengths from the manifold to the terminal fittings can be estimated from the above information and the resistance characteristics of the pipes. The examples presented below are for 15mm copper pipe in table 1 and for plastic pipework in table 2.

The preferred solution where space will allow



Table 1 : Maximum equivalent pipe length in 15mm copper

| Inlet pressure (bar) | Maximum equivalent length of pipe (m) | | |
|----------------------|---------------------------------------|----------|----------|
| | @ 8 l/m | @ 10 l/m | @ 18 l/m |
| 2.0 | 33 | 13 | 5 |
| 2.5 | 110 | 45 | 17 |
| 3.0 | 200 | 80 | 30 |

Table 2 : Maximum equivalent pipe lengths in plastic pipe

| Inlet pressure (bar) | Maximum equivalent length of pipe (m) | | |
|----------------------|---------------------------------------|-------------------------|-------------------------|
| | @ 8 l/m | @ 10 l/m | @ 18 l/m |
| 2.0 | 10mm: 2.0 15mm: 12.5 | 10mm: 1.3 15mm: 12.5 | 15mm: 4.5 22mm: 40 |
| 2.5 | 10mm: 4.0 | 10mm: 2.6 15mm: 25.0 | 15mm: 9.0 22mm: 80.0 |
| 3.0 | 10mm: 6.0 | 10mm: 3.9 15mm: 37.5 | 15mm: 13.5 22mm: 120 |

APPENDIX B

The size of the distribution pipes supplying the manifold should be calculated using the method set out in BS 6700. A typical diagrammatic arrangement of a system using Manifold Type 1 is shown below. This is only meant to show the principles involved and the actual connection of fittings to the manifold will need to suit the arrangements shown on page 35.

Note 1 - If it is proposed to fit chemical water treatment such as a water softener this should be fitted in this location and the cold water branch in the sink should be branched off the cold water main prior to the treatment device instead of the cold water manifold.

Any other isolating/control valves and backflow protection devices should be provided as necessary to comply with the Water Regulations.

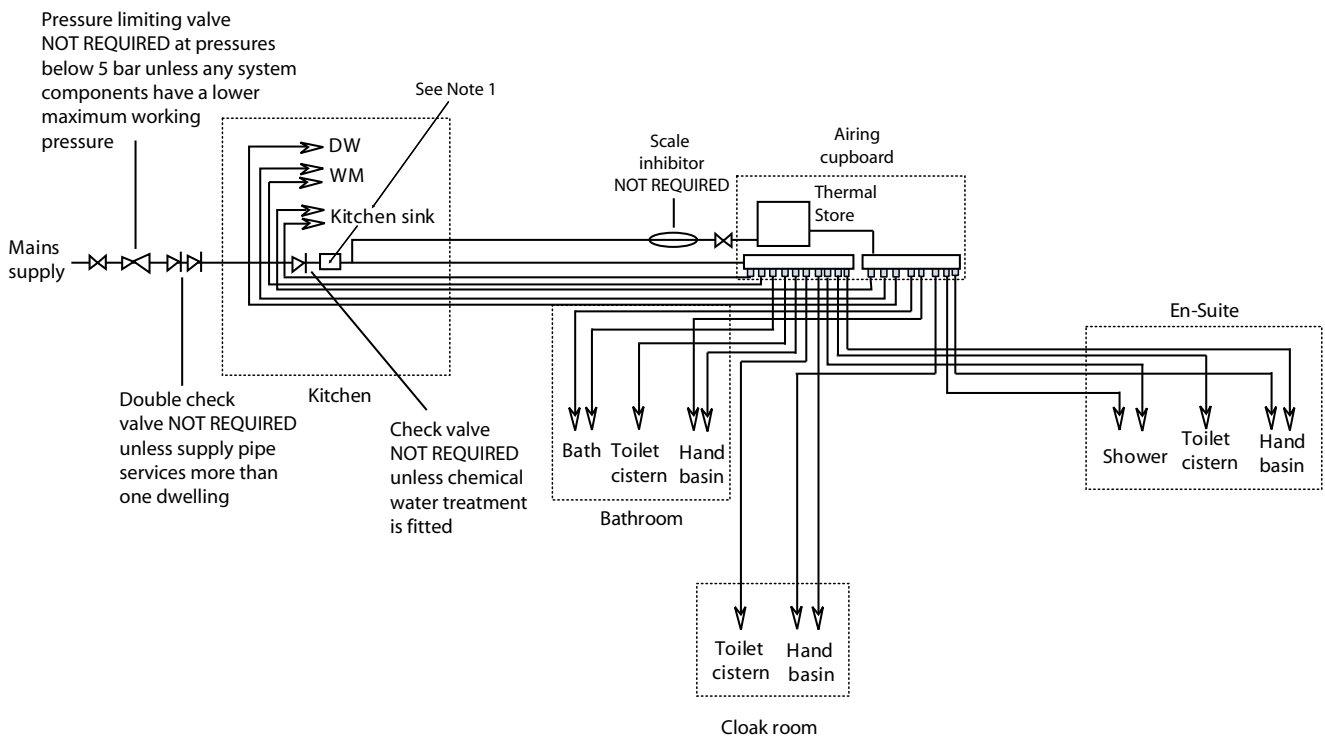

1. We only do business upon the Conditions which appear below and no other. Unless we so agree in writing these Conditions shall apply in full to any supply of goods by us to the exclusion of any Conditions or terms sought to be imposed by any purchaser. These Conditions of Sale and Warranty Terms override those which are contained on the Invoice Forms and all Sales are now subject to these Conditions of Sale and Warranty terms only.

2. PRICE

Orders are accepted at the price ruling at the date of receipt of order, this price is our last published list price plus a supplement to allow for any increase in the price of copper between the dates of publication of our price lists ("the copper price supplement"). An order may not be cancelled or varied after acceptance without the written consent of the company. Such cancellation or variation shall be subject to such reasonable charges as may be appropriate.

3. SPECIFICATION

The goods are supplied in accordance with the Specifications (if any) submitted to the Purchaser and any additions and alterations shall be the subject of an extra charge. Any goods not so specified shall be in accordance with our printed literature or the literature of any of our component suppliers (subject to any modifications made since publication). If we adopt any changes in construction or design of the goods, or in the specification printed in our literature, the Purchaser shall accept the goods so changed in fulfilment of the order.

4. PAYMENT

The invoice price of goods shall be payable within 30 days of despatch by us of our invoice for the goods or such longer time as may be stated by our quotation or invoice. If we receive payment in full on or before the due date we will allow a discount of 5% except where we have quoted a special net price. If payment is not received in full on or before the due date we shall be entitled in addition to the invoice price to:

- (i) payment of a sum equal to any increase in the copper price supplement applicable to the particular goods sold between the date of receipt of order and the date of receipt of payment in full; and
- (ii) interest on any part of the invoice price unpaid after the due date at the rate of 3% per annum over the base rate for the time being of Midland Bank plc.

5. TIME

We give estimates of delivery dates in good faith and time of delivery is not nor shall be made of the essence of any contract nor shall we be liable for any loss or damage occasioned by delay in delivery.

6. DELIVERY

We deliver free normally by our own vehicles within 25 miles of any of our manufacturing depots. Delivery to any place more than 25 miles from one of our manufacturing depots is subject to our quoted delivery charges. We reserve the right to make delivery of goods contained in one order by more than one consignment and at different times. Where a period is agreed for delivery and such period is not extended by our Agreement, the Purchaser shall take delivery within that period. If the Purchaser fails to take delivery, we shall be entitled at the Purchaser's risk and expense to store the goods at the Purchaser's premises or elsewhere and to demand payment as if they had been despatched. Offloading at point of delivery shall be the responsibility of and be undertaken by the Purchaser.

7. SHORTAGES OR DAMAGE

Goods must be inspected before signature of delivery note and any damage, shortage or discrepancy noted on the delivery note and the goods returned on the same vehicle. The buyer must also give us immediate written notice of the damage, shortage or discrepancy so that we may prompt investigation.

8. RETURN OF GOODS

Goods may not be returned to the Company except by prior written permission of an authorised officer of the Company and such return shall be subject to payment by the Purchaser of handling and re-stocking charges, transport and all other costs incurred by the Company.

9. COMPANY LIABILITY

All our goods are made of the best materials from reputable manufacturers and where stated are manufactured to the appropriate British Standard. Complaints must be given to us immediately, before any action is taken, as responsibility cannot be accepted if repairs or renewals are attempted on site without our written authority.

Where we agree to rectify any defect, we reserve the right to undertake the work on our own premises. Provided that our product has been installed in accordance with any instructions for installation any any relevant codes of practice and in accordance with the bye-laws and requirements obtaining in any particular area we give the following warranties:

(1) Domestic and Commercial Open Vented Cylinders and Tanks.

If the copper cylinder or tank or any integral pipework proves to be defective either in materials or workmanship, we will either repair or supply replacement at our option with the closest substitute in the case of any obsolete product to any address in Great Britain.

(a) free of all charge during the first year after delivery by us.

(b) thereafter at a charge of one-tenth of the then current list price and any copper price supplement and delivery charge during the second year after delivery by us and increasing by a further one-tenth on the second and subsequent anniversary of delivery by us.

AND FURTHER we will meet the contractors/installers reasonable costs in removing and replacing any defective Open Vented Copper Cylinder or Tank with defective integral pipework as follows:

- (i) in the case of vessels of less than 80 imperial gallons capacity up to a maximum of one-half of the extent of our liability in regard to the replacement product expressed in (1) (a) and (b) above
- (ii) in the case of vessels larger than 79 imperial gallons capacity up to a maximum of one-quarter of the extent of our liability in regard to the replacement product as expressed in paragraphs (1) (a) and (b) above.

(2) Domestic Mains Fed Products

If the copper storage vessel itself or any integral pipework as part of the storage vessel assembly proves to be defective either in materials or workmanship, we reserve the right to either repair or supply replacements or the closest possible substitute in the case of any obsolete product and will collect and deliver to any address in England, Wales and Scotland (excluding all Scottish Islands).

(a) free of all charge during the first year after delivery by us.

(b) thereafter at a charge of one-fifth of the then current list price or any copper price supplement and delivery charge during the second year after delivery by us increasing by a further one-fifth on the second and subsequent anniversary of delivery by us.

AND FURTHER we will meet the contractors/installers reasonable costs in removing and replacing any defective copper storage vessel or storage vessel with defective integral pipework from the Domestic Mains Pressure Range of products up to a maximum of one-third of the extent of our liability in regard to the replacement product expressed in (2) (a) and (b) above.

(3) Components of our products other than Storage Vessels and Integral Pipework. We will either extend to the purchaser the same terms of warranty as we are given by the manufacturer of the component or if the manufacturer does not give any warranty, replace free of charge any component which becomes defective within twelve months after the date of the delivery by us and is returned to us at the purchaser's expense but we shall not meet the cost of removal or shipping or return of the component or any other cost charges or damages incurred by the purchaser.

(4) In the case of the Gulfstream range of products any heat generator found to be defective and admitted to be such by us either as regards materials or workmanship within 12 months from date of installation or 18 months from date of manufacture whichever is the sooner, will be repaired or replaced at our option. **AND FURTHER** we will meet the contractors/installers reasonable costs in removing and replacing any defective heat generator up to a maximum of one-third of the extent of our liability in regard to the replacement product.

(5) In the case of goods manufactured solely in accordance with our specification and designs and in respect of any installation work carried out by or on our behalf, our entire liability and the purchaser's sole remedies (subject to (1-4) above) and shall be as follows:

(a) we accept liability for death or personal injury to the extent that it results from our negligence that of our employees agents or subcontractors.

(b) subject to paragraph (d) below, we accept liability for direct physical damage to tangible property to the extent that such damage is caused by our negligence that of our employees agents or subcontractors.

(c) our total liability to the purchaser over and above any liability to replace under (1 - 4) above (whether in contract or in tort including negligence) in respect of any one cause of loss or damage claimed to result from any breach of our obligations hereunder, shall be limited to actual money damages which shall not exceed £20,000 provided that such monetary limit shall not apply to any liability on the part of ourselves referred to in paragraph (a) above.

(d) except as provided in paragraph (a) above but otherwise notwithstanding any provision herein contained in no event shall we be liable for the following loss or damage howsoever caused and even if foreseeable by us or in our contemplation :-

(i) economic loss which shall include loss of profits, business revenue, goodwill or anticipated savings.

(ii) damages in respect of special indirect or consequential loss or damage (other than death, personal injury and damage to tangible property).

(iii) any claim made against the purchaser by any other party (save as expressly provided in paragraph (b) above).

(e) except in respect of our liability referred to in paragraph (a) above no claim may be made or action brought (whether in contract or in tort including negligence) by the purchaser in respect of any goods supplied by us more than one year after the date of the invoice for the relevant goods.

(f) nothing in these Conditions shall confer on the purchaser any rights or remedies to which the purchaser would not otherwise be legally entitled.

(6) Notwithstanding any other provision contained herein the Purchaser's hereby agree to fully indemnify us against any damages losses costs claims or expenses incurred by us in respect of any claim brought against us by any third party for :-

(a) any loss injury or damage wholly or partly caused by any goods supplied by us or their use.

(b) any loss injury or damage wholly or partly caused by the defective installation or sub-standard workmanship or materials used in the installation of any goods supplied by us.

(c) any loss injury or damage in any way connected with the performance of this contract.

PROVIDED that this paragraph (6) will not require the Purchaser to indemnify us against any liability for our own acts of negligence or those of our employees agents or sub-contractors.

FURTHER in the case of goods supplied by us which are re-sold to and installed by a third party by the Purchaser it will be the sole responsibility of the Purchaser to test the goods immediately after their installation to ensure that inter alia they are correctly installed and are in proper working order, and are not likely to cause any loss injury or damage to any person or property.

10. VARIATION OF WARRANTY AND EXCLUSION

Should our warranty and exclusion be unacceptable we are prepared to negotiate for variation in their terms but only on the basis of an increase in the price to allow for any additional liability or risk which may result from the variation.

Purchasers are advised to insure against any risk or liability which they may incur and which is not covered by our warranty.

11. RISK AND RETENTION OF TITLE

(a) goods supplied by us shall be at the Purchaser's risk immediately upon delivery to the Purchaser or into custody on the Purchaser's behalf or to the Purchaser's Order. The Purchaser shall effect adequate insurance of the goods against all risks to the full invoice value of the goods, such insurance to be effective from the time of delivery until property in the goods shall pass to the Purchaser as hereinafter provided.

(b) property in the goods supplied hereunder will pass to the Purchaser when full payment has been made by the Purchaser to us for :-

(i) the goods of the subject of this contract.

(ii) all other goods the subject of of any other contract between the Purchaser and us which, at the time of payment of the full price of the goods sold under this contract, have been delivered to the Purchaser but not paid for in full.

(c) until property in the goods supplied hereunder passes to the Purchaser in accordance with paragraph (2) above.

(i) the Purchaser shall hold the goods in a fiduciary capacity for us and shall store the same separately from any other goods in the Purchaser's possession and in a manner which enables them to be identified as our goods.

(ii) the Purchaser shall immediately return the goods to us should our authorised representative so request. All the necessary incidents associated with a fiduciary relationship shall apply.

(d) the Purchaser's right to possess the goods shall cease forthwith upon the happening of any of the following events, namely :-

(i) if the Purchaser fails to make payment in full for the goods within the time stipulated in clause 4 hereof.

(ii) if the Purchaser, not being a company, commits any act of bankruptcy, makes a proposal to his or her creditors for a compromise or does anything which would entitle a petition for a Bankruptcy Order to be presented.

(iii) if the Purchaser, being a company, does anything or fails to do anything which would entitle an administrator or an administrative receiver or a receiver to take possession of any assets or which would entitle any person to present a petition for winding up or to apply for an administration order.

(e) the Purchaser hereby grants to us an irrevocable licence to enter at any time any vehicle or premises owned or occupied by the Purchaser or in the possession of the Purchaser for the purposes of repossessing and recovering any such goods the property in which has remained in us under paragraph (2) above. We shall not be responsible for and the Purchaser will indemnify us against liability in respect of damage caused to any vehicle or premises in such repossession and removal being damaged which it was not reasonably practicable to avoid.

(f) notwithstanding paragraph (3) hereof and subject to paragraph (7) hereof, the Purchaser shall be permitted to sell the goods to third parties in the normal course of business. In this respect the Purchaser shall act in the capacity of our commission agent and the proceeds of such sale :-

(i) shall be held in trust for us in a manner which enables such proceeds to be identified as such, and :

(ii) shall not be mixed with other monies nor paid into an overdrawn bank account.

We, as principal, shall remunerate the Purchaser as commission agent a commission depending upon the surplus which the Purchaser can obtain over and above the sum, stipulated in this contract of supply which will satisfy us.

(g) in the event that the Purchaser shall sell any of the goods pursuant to clause (6) hereof, the Purchaser shall forthwith inform us in writing of such sale and of the identity and address of the third party to whom the goods have been sold.

(h) if, before property in the goods passes to the Purchaser under paragraph (2) above the goods are or become affixed to any land or building owned by the Purchaser it is hereby agreed and declared that such affixation shall not have the effect of passing property in the goods to the Purchaser. Furthermore if, before property in the goods shall pass to the Purchaser under paragraph (2) hereof, the goods are or become affixed to any land or building (whether or not owned by the Purchaser), the Purchaser shall:-

(i) ensure that the goods are capable of being removed without material injury to such land or building.

(ii) take all necessary steps to prevent title to the goods from passing to the landlord of such land or building.

(iii) forthwith inform us in writing of such affixation and of the address of the land or building concerned.

The Purchaser warrants to repair and make good any damage caused by the affixation of the goods to or their removal from any land or building and to indemnify us against all loss damage or liability we may incur or sustain as a result of affixation or removal.

(i) in the event that, before property in the goods has passed to the Purchaser under paragraph (2) hereof, the goods or any of them are lost, stolen, damaged or destroyed :-

(i) the Purchaser shall forthwith inform us in writing of the fact and circumstances of such loss, theft, damage or destruction.

(ii) the Purchaser shall assign to us the benefit of any insurance claim in respect of the goods so lost, stolen, damaged or destroyed.

12. NON-PAYMENT

If the Purchaser shall fail to make full payment for the goods supplied hereunder within the time stipulated in clause 4 hereof or be in default of payment for any other reason then, without prejudice to any of our other rights hereunder, we shall be entitled to stop all deliveries of goods and materials to the Purchaser, including deliveries or further deliveries of goods under this contract. In addition we shall be entitled to terminate all outstanding orders.

13. RISK

All goods sold by us shall be at the sole risk of the Purchaser from the date of despatch by us of the invoice for their price.

14. VALUE ADDED TAX

All prices quoted are exclusive of Value Added Tax which will be charged at the rate ruling at the date of despatch of invoice.

15. TRADE SALES ONLY

We are only prepared to deal with those who are not consumers within the terms of the Unfair Contract Terms Act 1977, the Sale of Goods Act 1979 and the Supply of Goods and Services Act 1982. Accordingly any person who purchases from us shall be deemed to have represented that he is not a consumer by so purchasing.

16. JURISDICTION

The agreement is subject to English/Scots law and any dispute arising hereunder shall be settled in accordance therewith dependent upon the location.

